

Thermo Scientific Ramsey Microwave Point Level Detector

Non-Contacting Point Level Detection

The Thermo Scientific Ramsey Microwave Point Level Detector is a reliable instrument that can see through non-metallic wall build-up and detect the presence or absence of any material. By detecting the conditions in your equipment, it will alert you of any problems or disruptions in your process, allowing you to efficiently rectify the situation. This will save you time and money.

Features and Benefits

- Non-contact point level detection
- Completely safe low power microwave energy can see through non-conductive materials
- Highly adjustable sensitivity allows use in many different applications
- Alarm relay is user selectable for normal/alarm conditions
- User adjustable time delays to prevent false alarms
- Time delay for both alarm on and alarm off

Thermo Scientific Ramsey Remote Microwave System (RMS-2) Amplifier/Control



Thermo Scientific Ramsey Integral Microwave System (IMS-2) Sender, Receiver and Amplifier/Control



The Thermo Scientific Ramsey Microwave Point Level Detector uses a separate sender and receiver to detect the presence or absence of any material with low power microwave energy. It is a totally noncontacting instrument that is a safe and environmentally friendly replacement for nucleonic switches and is not restricted by OSHA or FCC regulations.

These reliable units have a range from 10 cm (4 in) minimum to 150 m (492 ft) maximum and can see through non-metallic wall build-up.

Theory of Operation

In operation the sender and receiver are mounted facing each other on opposite sides of the chute or vessel to be monitored. The sender emits a burst of microwave energy many times per second toward the receiver which detects and measures the energy. When the line of sight between the sender and receiver is blocked by material, the microwave energy reaching the receiver will be reduced.

The amplifier determines whether the detected microwave energy indicates the presence of material and controls the status of the alarm relay to match. Sensitivity settings in the amplifier allow the user to calibrate the units for a wide range of applications. Time delays and relay settings allow the user to customize the relay control to their specific application needs.

The microwaves used by the unit will penetrate non-conductive materials. Various mounting brackets and microwave permeable process windows are available, allowing the sender and receiver to be placed outside of the process, preventing the influence of high temperatures or harsh conditions inside.

These units can detect high or low level in many applications such as:

- Pressurized coal downcomers
- Electro-static precipitator hoppers
- Transfer chutes for fly ash, clinker, coal, potash and other materials

 INGEPROA

thermo
scientific

Authorized Distributor

The Thermo Scientific Ramsey Microwave Point Level Detector is available in two configurations. The IMS-2 (Integral Microwave System) is a two piece system with a separate sender and receiver. The amplifier electronics are integral to the IMS-2 receiver. The RMS-2 (Remote Microwave System) is a three piece system with a separate sender, receiver and amplifier enclosure.

Thermo Scientific Ramsey Microwave Point Level Detector

General Specifications

Input Power	90-260 VAC (±15%), 50/60 Hz and 24 VDC
Operating Frequency	10.525 GHz, ±25 MHz
RF Power Density	Approximately 20 µW/cm ² , caution sign not required
Beam Angle	3 dB beam angle approximately 30°, linearly polarized field
Operating Range	Minimum distance of 10 cm (4 in) up to 150 m (492 ft) under ideal conditions
Output Relay	SPDT rated 5 amps at 240 VAC resistive
Failsafe	Selectable high level or low level fail safe operation
Relay Time Delay	Two 0.1 to 20 second adjustable relay time delays (on delay and off delay)
Calibration	Full range sensitivity adjustment to match application requirements
Operating Temperature	-30°C to +65°C (-20°F to +150°F)

Thermo Scientific Ramsey Microwave Point Level Detector – Physical Dimensions

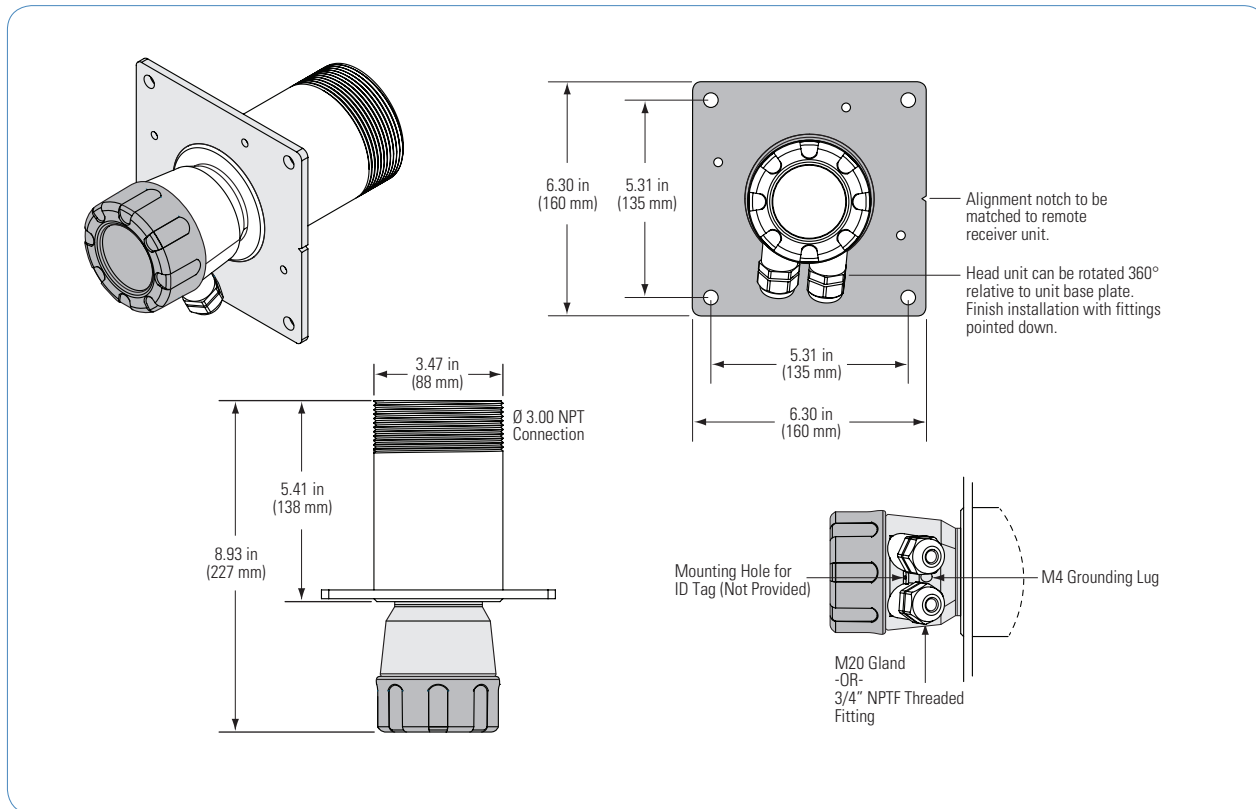

thermoscientific.com/bulkweighing

© 2014 Thermo Fisher Scientific Inc. All rights reserved. All trademarks are the property of Thermo Fisher Scientific Inc. and its subsidiaries. Specifications, terms and pricing are subject to change. Not all products are available in all countries. Please consult your local sales representative for details.

Australia +61 (0) 8 8208 8200 +61 (0) 8 8234 3772 fax	Chile +56 (0) 2 378 5080 +56 (0) 2 370 1082 fax	India +91 (20) 6626 7000 +91 (20) 6626 7001 fax	South Africa +27 (0) 11-822-4120 +27 (0) 11-822-3982 fax	United States & Canada +1 (800) 445-3503 +1 (763) 783-2525 fax +1 (763) 783-2500 direct
Brazil +55-11-2367-2192 +55-11-2367-2192 fax	China +86 (0) 80 0810 5118 +86 (0) 21 6445 1101 fax	Italy +39 02-950590-55 +39 02-953200-15 fax	Spain +34 (0) 91-484-5965 +34 (0) 91-484-3597 fax	
Pl.8026.0214	Germany +49 (0) 208-824930 +49 (0) 208-852310 fax	Mexico +52 (55) 1253 9410 +52 (55) 1253 9424 fax	United Kingdom +44 (14) 4241 3700	