

PRODUCT SPECIFICATIONS

INGEPROA Hammer Mill. Model CS31/3SM

Ore Size Reduction for a Bulk Material.



The INGEPROA CS-31 series hammer mills are compact grinding machines for all types of slate and clay with a maximum moisture content of 10%.

The wide variety of models allows us to cover wide ranges of productions.

The adjustable breaker and the wide variety of sieves allow to regulate the granulometric reduction in each case. The resulting product presents a homogeneous and uniform appearance.

The crushing of the material occurs in two phases:

- Primary break of the incoming material by hammer speed.
- Impacts of the material against adjustable breakers.

Finally, a granulometric screening of the material is carried out using a system of perforated grills of different configurations and finishes depending on the needs of the final product.

The Hammer mill consist of a series of oscillating hammers and includes a grill to obtain the fine size of the product.



The material is reduced initially in the upper chamber by impact, then is further reduced by shearing process and finally reduced by attrition as forces the material through the grill

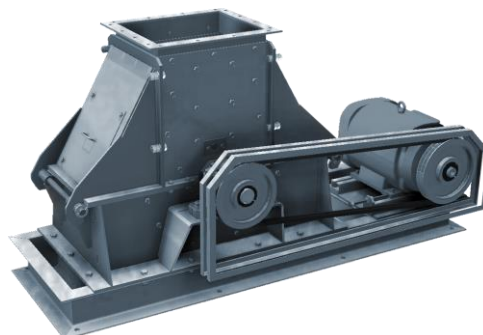

Features:

- Reduction and variation of granulometry according to customer requirements
- Exclusive system of internal heating
- Compact and highly productive installations
- Maximum energy efficiency
- Interchangeable anti-wear hammers
- Adjustable breaking Plates
- Areas subject to wear protected by interchangeable elements made by special steel
- Inspection door
- Optional grill heating
- Safety according to UNE EN 12100 Standard



The hammer mills incorporate two large flywheel sides that guarantee a smooth and silent running, while stabilizing the power consumed.

According to the models, they are provided with two heat sources adjustable by tubular armored resistances located in the front side or front/back side.

This prevents the material from adhering to the surfaces, thus being able to work in this way at full capacity with clay containing a high percentage of moisture

Ingeproa's Hammer mills are flexible, and can be used in a variety of applications. Because of their heavy-duty construction and high capacity processing capabilities, hammer mills are most commonly utilized in mineral agglomeration and fertilizer production applications.

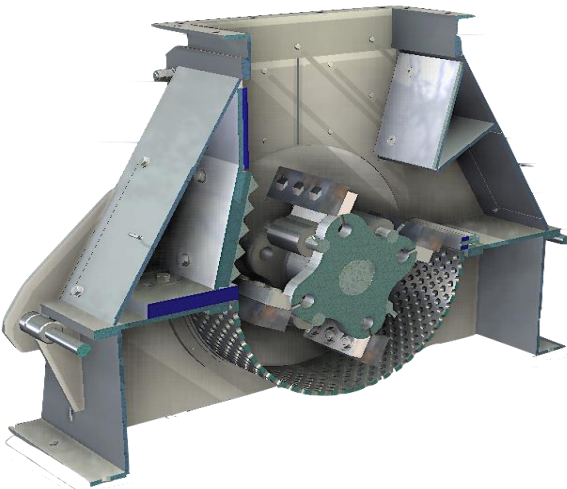

MODEL	CS-31 / 3SM
APPROXIMATE PRODUCTION	2 - 5 m ³ /h
MILL WEIGHT	570 Kg
PLATE WEIGHT	160 Kg
DRIVES WEIGHT	217 Kg
TOTAL WEIGHT	1060 Kg
HAMMERS NUMBER	8
INPUT HOPPER	14.015" x 17.716" (356x450) mm
OUTPUT HOPPER	14.488" x 38.582" (368x980) mm
MILL PULEY	SPB-2C Øs: 11.023" (280 mm)
DRIVE PULLEY	SPB-2C Øs: 9.842" (250 mm)
DRIVE	SEW-Eurodrive 15 KW (20Hp) IP 65, F isolation

INGEPROA hammer mills feature a removable quarter panel for easy access and simplified maintenance, as well as a non-clogging design: ample clearance within the machine helps to aid the flow of material, preventing build-up and subsequent downtime.



Alloy material for high performance

To maintain optimal product performance, you need immediate access to experts worldwide, as well as priority status when your air quality equipment needs repair or replacement. We offer comprehensive, flexible support solutions for all phases of the product life cycle. Through predictable, fixed-cost pricing, our services help protect the return on investment and total cost of ownership of your Thermo Scientific products. For more information on our comprehensive.

Service solutions visit ingeproa.com

SPAIN
 Paseo de Sagasta, 4, 7º
 50.008. -Zaragoza
 Ph: (0034) 634 548021
 Fax: (0034) 876 036437
info@ingeproa.com