

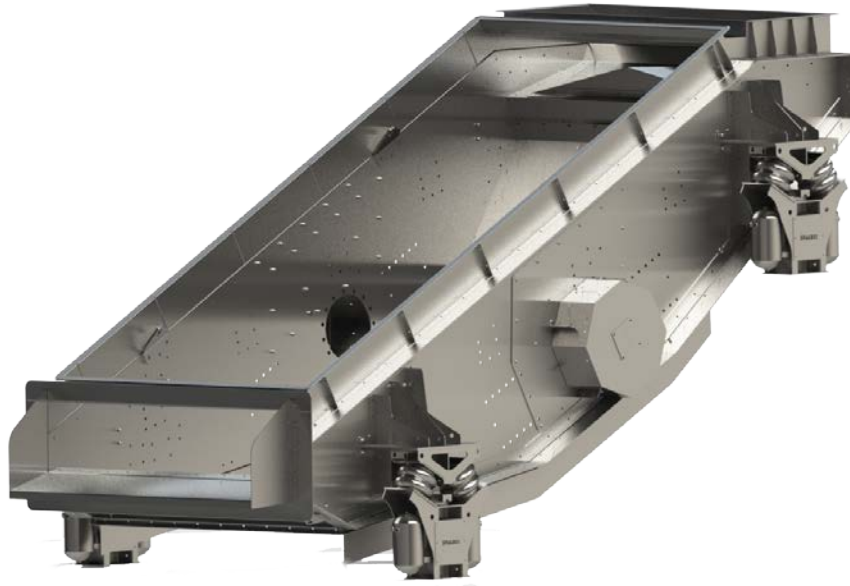

## VIBRATING SCREENER FEEDER (VF)



### General Characteristics

<b>Model</b>	VIBRATING SCREENER VF
<b>Construction</b>	Reinforced Carbon Steel
<b>Grids</b>	Steel, Stainless-steel, polyurethane, Rubber
<b>Floors</b>	1 to 3

### Advantages

Vibrating screens can classify most materials, from powdery materials to materials of considerable dimensions, with very low wear and minimal maintenance. Materials are screened by micro-screening. The material is forced to impinge directly against the screening surface a precise number of times per second.

Vibration screening is gentle and respectful of the material, causing minimal material degradation. Vibrating screens can be supplied sealed to prevent material leakage and protect the environment.

Lineal or circular movement.  
Non-Vibrating elements included  
Open or close concept.

### Application Sectors

**Mining**  
**Recycling**  
**Agri-food industry**  
**Waste Applications**  
**Bulk Materials**  
**Automotive**

### CE Normative

This partly completed machine is in compliance with the following relevant provisions of the EC Directives: 2004/108/EC (EMC Directive).

The protection objectives of the Low Voltage Directive 2006/95/EC are in accordance with Annex I, No. 1.5.1 of the EC Machinery Directive 2006/42/EC.

The following standards have also been applied:

EN ISO 12100-1:2003.  
EN ISO 12100-2:2003.  
EN ISO 13857:2008.  
And EN 619:2002.

