

SLOTTED-VESSEL SAMPLERS (CSB-100)

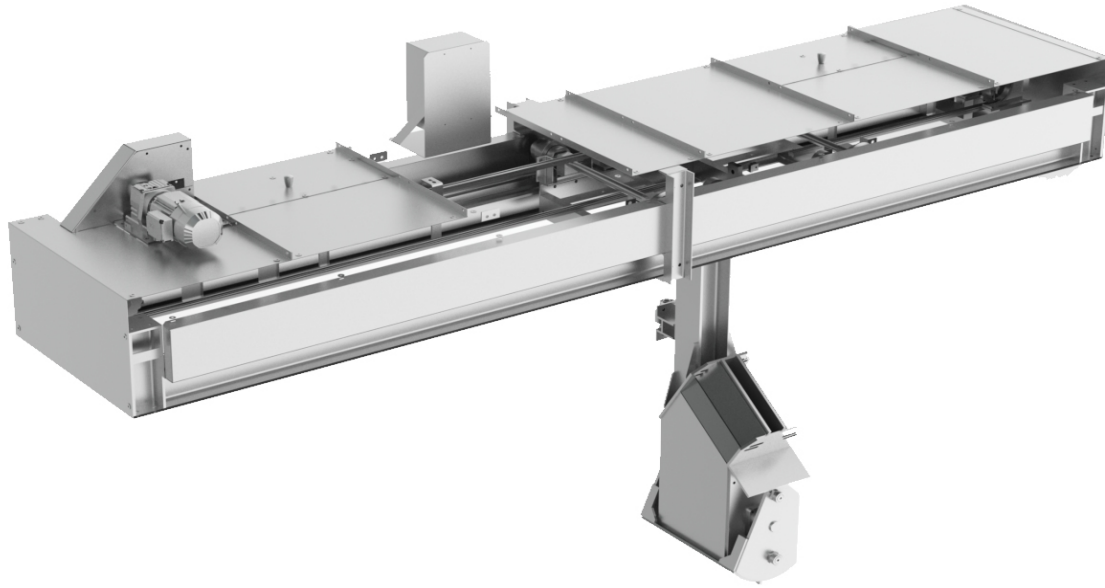

General Characteristics

Model	CSB-100
Width Belt	800, 1000, 1200mm
Cutter Width	Modular, depending Final sample per lot
Gear Box	SEW, NORD or Similar
Stroke	1200 – 2500 mm

Advantages

The slotted-vessel sampler runs through the material stream from the waiting position with the base flap usually opened, closing this flap when the reverse position is reached.

The sampler now runs through the product stream with the base flap closed again at constant speed and thus takes a representative sample.

On the usually conical vessel reaching its waiting position, the base flap is opened by means of stops and a sophisticated lever system, and the slotted-vessel emptied.

The sampler's waiting position is invariably located outside the material stream, thus minimizing wear to the sampler.

Sampling Normative

Some of these groups are:

1. American Society for Testing and Materials (A.S.T.M.).
2. International Organization for Standardization (I.S.O.).
3. Japanese Industrial Standards (J.I.S.).
4. GOST Normative

CE Normative

This partly completed machine is in compliance with the following relevant provisions of the EC Directives: 2004/108/EC (EMC Directive).

The protection objectives of the Low Voltage Directive 2006/95/EC are in accordance with Annex I, No. 1.5.1 of the EC Machinery Directive 2006/42/EC.

The following standards have also been applied:

EN ISO 12100-1:2003.

EN ISO 12100-2:2003.

EN ISO 13857:2008.

And EN 619:2002.

